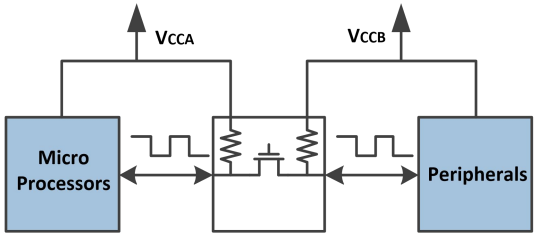

GT0108 8-Bit Bidirectional Voltage-Level Translator

1 Features	2 Application
<ul style="list-style-type: none"> - No direction-control - Data rates 24 Mbps (Push Pull) 2 Mbps (Open Drain) - 1.65 V to 3.6 V on A port and 2.3 V to 5.5 V on B port ($V_{CCA} \leq V_{CCB}$) - VCC isolation feature: If either VCC input is at GND, both ports are in the high-impedance state - No power-supply sequencing required: either V_{CCA} or V_{CCB} can be ramped first - I_{off} supports partial-power-down mode operation - Operating temperature range: -40°C to $+85^{\circ}\text{C}$ 	<ul style="list-style-type: none"> - Handset/Smartphone - MART - IPC - GPIO

3 Description	Circuit Diagram
<p>This 8-bit non-inverting translator which is a bidirectional voltage-level translator and can be used to build digital switching compatibility between multi voltage systems. This IC uses two separate configurable power supply tracks that including A ports supporting operating voltages from 1.65 V to 3.6 V with tracking V_{CCA} supply, and also including B ports supporting operating voltages from 2.3 V to 5.5 V with tracking V_{CCB} supply.</p> <p>The advantage above provides the support of both lower and higher logic signal levels while providing bidirectional translation capabilities between any of the 1.8-V, 2.5-V, 3.3-V, and 5- V voltage circuit points.</p> <p>Placing output-enable (OE) input to low level, all I/Os are forced to high-impedance state that significantly lower the quiescent current consumption. In order to ensure the high-impedance state during power up or power down, OE pin should be tied to GND via a pull-down resistor; the minimum value of the resistor is determined by the current-sourcing capability of the driver.</p>	

4 Revision History

Revision	Date	Note
Rev.A1.0	2023. 09. 21	Original Version
Rev.A1.1	2023. 09. 09	Additional Switch Characteristics Data
Rev.A1.2	2023. 10. 24	1.Updated Package Qty 2.Added Tape and Reel Information
Rev.A1.3	2023. 12. 18	Updated New Package BQG
Rev.A1.4	2024. 01. 26	Updated Part Name

The latest datasheet version should be checked on the GTIC official website, as the company does not actively inform customers about updates to the datasheet.

5 Device Summary, Pin and Packages

Table 5-1. Device Summary⁽¹⁾

Serial Name	Part Name	Package	Body Size (Nom)	Marking ⁽²⁾	MSL ⁽³⁾	Package Qty
GT0108	GT0108TG	TSSOP-20	6.50mm×4.40mm	GT0108 XXXXXXX	3	Tape and Reel,4000
	GT0108BQG	QFN3×3-20L	3.00mm×3.00mm	GT0108B XXXXX	3	Tape and Reel,5000
	GT0108QG	QFN3×3-20L	3.00mm×3.00mm	GT0108 XXXXX	3	Tape and Reel,5000

(1)For all available packages, please contact product sales.

(2)There may be additional marking, which relates to the lot trace code information (data code and Vendor code), the logo or the environmental category on the device.

(3)MSL, The Moisture Sensitivity Level rating according to the JEDEC industry standard classifications.

(4)"XXXXX" in Marking will be appeared as the batch code.

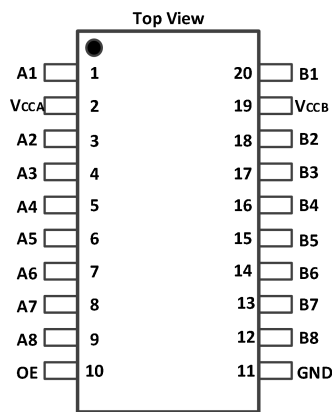
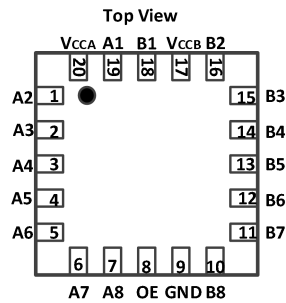
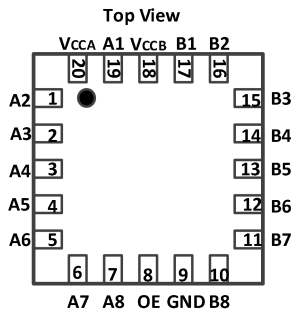
Fig.5-1. GT0108: TG (TSSOP-20) Package

Fig.5-2. GT0108: BQG (QFN3×3-20L) Package

Fig.5-3. GT0108: QG (QFN3×3-20L) Package

5 Device Summary, Pin and Packages (Continued)

Table 5-2. Pin Definition

NAME	PIN			I/O	Function
	TG	BQG	QG		
A1	1	19	19	I/O	Input/Output 1. Referenced to V _{CCA} .
V _{CCA}	2	20	20	-	A-Port power supply.
A2	3	1	1	I/O	Input/Output 2. Referenced to V _{CCA} .
A3	4	2	2	I/O	Input/Output 3. Referenced to V _{CCA} .
A4	5	3	3	I/O	Input/Output 4. Referenced to V _{CCA} .
A5	6	4	4	I/O	Input/Output 5. Referenced to V _{CCA} .
A6	7	5	5	I/O	Input/Output 6. Referenced to V _{CCA} .
A7	8	6	6	I/O	Input/Output 7. Referenced to V _{CCA} .
A8	9	7	7	I/O	Input/Output 8. Referenced to V _{CCA} .
OE	10	8	8	I	Tri-state output mode. Pull low put all outputs in tri-state. Referenced to V _{CCA}
GND	11	9	9	-	Ground
B8	12	10	10	I/O	Input/Output 8. Referenced to V _{CCB}
B7	13	11	11	I/O	Input/Output 7. Referenced to V _{CCB}
B6	14	12	12	I/O	Input/Output 6. Referenced to V _{CCB}
B5	15	13	13	I/O	Input/Output 5. Referenced to V _{CCB}
B4	16	14	14	I/O	Input/Output 4. Referenced to V _{CCB}
B3	17	15	15	I/O	Input/Output 3. Referenced to V _{CCB}
B2	18	16	16	I/O	Input/Output 2. Referenced to V _{CCB}
V _{CCB}	19	17	18	-	B-Port power supply
B1	20	18	17	I/O	Input/Output 1. Referenced to V _{CCB}

*It is suggested to leave the unconnected pins floating.

6 Voltage, Temperature, ESD and Thermal Ratings

6.1 Absolute Maximum Ratings

Parameters	Min	Max	Unit
Supply voltage, V _{CCA}	-0.3	6.0	V
Supply voltage, V _{CCB}	-0.3	6.0	V
Input voltage range, V _I	A port	-0.3	6.0
	B port	-0.3	6.0
Voltage range applied to any output in the high-impedance or power-off state, V _o	A port	-0.3	6.0
	B port	-0.3	6.0
Voltage range applied to any output in the high or low state, V _o	A port	-0.3	V _{CCA} +0.3
	B port	-0.3	V _{CCA} +0.3
Input clamp current, I _{IK}	V _I <0	-50	mA
Output clamp current, I _{OK}	V _o <0	-50	mA
Continuous output current, I _o		± 50	mA
Continuous current through V _{CCA} , V _{CCB} or GND		± 100	mA
Maximum junction temperature		150	°C
Storage temperature range	-65	150	°C

(1)Stresses above these ratings may cause permanent damage. Exposure to absolute maximum conditions for extended periods may degrade device reliability. These are stress ratings only, and functional operation of the device at these or any other conditions beyond those specified is not implied.

(2)The input and output negative-voltage ratings may be exceeded if the input and output current ratings are observed

(3)The value of V_{CCA} and V_{CCB} are provided in the recommended operating conditions table.

6 Voltage, Temperature, ESD and Thermal Ratings(Continued)

6.2 ESD Ratings

ESD		Value	Unit	
V(ESD)	Electrostatic Discharge	Human-Body Model (HBM)	±3K	V
		Machine Model (CDM)	±2K	V

(1) JEDEC document JEP155 states that 500-V HBM allows safe manufacturing with a standard ESD control process.

(2) JEDEC document JEP157 states that 250-V CDM allows safe manufacturing with a standard ESD control process.

6.3 Recommended Operating Conditions⁽³⁾

V_{CCI} is the supply voltage associated with the input port. V_{CCO} is the supply Voltage associated with the output port.

Parameter	Conditions	Min	Typ	Max	Unit
Supply voltage ⁽¹⁾	V_{CCA}	1.65		3.6	V
	V_{CCB}	2.3		5.5	
High-level input voltage(V_{IH})	A-port I/Os	$V_{CCA}=1.65\text{ V to }1.95\text{ V}$ $V_{CCB}=2.3\text{ V to }5.5\text{ V}$	$V_{CCI}-0.2$	V_{CCI}	V
		$V_{CCA}=2.3\text{ V to }3.6\text{ V}$ $V_{CCB}=2.3\text{ V to }5.5\text{ V}$	$V_{CCI}-0.4$	V_{CCI}	
	B-port I/Os	$V_{CCA}=1.65\text{ V to }3.6\text{ V}$ $V_{CCB}=2.3\text{ V to }5.5\text{ V}$	$V_{CCI}-0.4$	V_{CCI}	
OE input	$V_{CCA}=1.65\text{ V to }3.6\text{ V}$ $V_{CCB}=2.3\text{ V to }5.5\text{ V}$	$V_{CCI} \times 0.8$		5.5	
Low-level input voltage(V_{IL}) ⁽²⁾	A-port I/Os	$V_{CCA}=1.65\text{ V to }1.95\text{ V}$ $V_{CCB}=2.3\text{ V to }5.5\text{ V}$	0	0.15	V
	B-port I/Os	$V_{CCA}=1.65\text{ V to }3.6\text{ V}$ $V_{CCB}=2.3\text{ V to }5.5\text{ V}$	0	0.15	
OE	OE input	$V_{CCA}=1.65\text{ V to }3.6\text{ V}$ $V_{CCB}=2.3\text{ V to }5.5\text{ V}$	0	$V_{CCA} \times 0.25$	V
Input transition rise or fall rate($\Delta t/\Delta v$)	A-port I/Os push-pull driving			10	ns/V
	B-port I/Os push-pull driving			10	
	Control input			10	
TA Operating free-air temperature	-	-40		85	°C

(1) V_{CCA} must be less than or equal to V_{CCB} .

(2)The maximum V_{IL} value is provided to ensure that a valid V_{OL} is maintained. The V_{OL} value is V_{IL} plus the voltage drop across the pass gate transistor.

7 Electrical Specifications

7.1 Electrical Characteristics

over recommended operating free-air temperature range (unless otherwise noted) ⁽¹⁾ ⁽²⁾ ⁽³⁾

Parameter		Conditions	V _{CCA}	V _{CCB}	Temp	Min	Typ	Max	Unit
V _{OHA}	Port A Output High Voltage	I _{OH} =-20 μA V _{IB} ≥ V _{CCB} - 0.4V	1.65V to 3.6V	2.3V to 5.5V	Full	V _{CCA} ×0.7			V
V _{OLA}	Port A Output Low Voltage	I _{OL} =1mA V _{IB} ≤ 0.15 V	1.65V to 3.6V	2.3V to 5.5V	Full			0.3	V
V _{OHB}	Port B Output High Voltage	I _{OH} =-20 μA V _{IA} ≥ V _{CCA} - 0.4V	1.65V to 3.6V	2.3V to 5.5V	Full	V _{CCA} ×0.7			V
V _{OLB}	Port B Output Low Voltage	I _{OL} =1mA V _{IA} ≤ 0.15 V	1.65V to 3.6V	2.3V to 5.5V	Full			0.3	V
I _I	Input Leakage Current	OE	1.65V to 3.6V	2.3V to 5.5V	+25°C			±1	μA
					Full			±1.5	
I _{off}	Partial Power Down Current	A Ports	0V	0V to 5.5V	+25°C			±0.5	μA
					Full			±1	
		B Ports	0V to 3.6V	0V	+25°C			±0.5	
					Full			±1	
I _{oz}	High-impedance State Output Current	A or B port OE=0V	1.65V to 3.6V	2.3V to 5.5V	+25°C			±0.5	μA
					Full			±1	
I _{CCA}	V _{CCA} Supply Current	V _I =V _O =open I _O =0	1.65V to V _{CCB}	2.3v to 5.5V	Full			2.5	μA
			3.6v	0V	Full			2.5	
			0v	5.5V	Full			-1	
I _{CCB}	V _{CCB} Supply Current	V _I =V _O =open I _O =0	1.65V to V _{CCB}	2.3v to 5.5V	Full			10	μA
			3.6v	0V	Full			-1	
			0v	5.5V	Full			1	
I _{CCA} + I _{CCB}	Combined Supply Current	V _I =V _{CC1} or GND I _O =0	1.65V to V _{CCB}	2.3v to 5.5V	Full			13	μA
I _{CCZA}	V _{CCA} Supply Current	V _I =V _{CC1} or 0V I _O =0, OE=0V	1.65V to V _{CCB}	2.3v to 5.5V	Full			1	μA
I _{CCZB}	V _{CCB} Supply Current	V _I =V _{CC1} or 0V I _O =0, OE=0V	2.3v to 3.6V	2.3v to 5.5V	Full			1	μA
C _i	Input Capacitance	OE	3.3V	3.3V	+25°C		2.5		PF
C _{io}	Input-to-output Internal Capacitance	A Port	3.3V	3.3V	+25°C		5		PF
		B Port	3.3V	3.3V	+25°C		5		

(1) V_{CC1} is the VCC associated with the input port.

(2) V_{CC0} is the VCC associated with the output port

(3) V_{CCA} must be less than or equal to V_{CCB}.

7 Electrical Specifications (Continued)

7.2 Timing Requirements

$V_{CCA}=1.8V \pm 0.15V$

		$V_{CCB}=2.5V \pm 0.2V$	$V_{CCB}=3.3V \pm 0.2V$	$V_{CCB}=5V \pm 0.2V$	Unit
		Typ	Typ	Typ	
Data Rate	Push-pull Driving	21	22	24	Mbps
	Open-drain Driving	2	2	2	
Pulse Duration(tw)	Push-pull Driving (Data Inputs)	47	45	41	ns
	Open-drain Driving (Data Inputs)	500	500	500	

$V_{CCA}=2.5V \pm 0.15V$

		$V_{CCB}=2.5V \pm 0.2V$	$V_{CCB}=3.3V \pm 0.2V$	$V_{CCB}=5V \pm 0.2V$	Unit
		Typ	Typ	Typ	
Data Rate	Push-pull Driving	20	22	24	Mbps
	Open-drain Driving	2	2	2	
Pulse Duration(tw)	Push-pull Driving (Data Inputs)	50	45	41	ns
	Open-drain Driving (Data Inputs)	500	500	500	

$V_{CCA}=3.3V \pm 0.15V$

		$V_{CCB}=3.3V \pm 0.2V$	$V_{CCB}=5V \pm 0.2V$	Unit
		Typ	Typ	
Data Rate	Push-pull Driving	23	24	Mbps
	Open-drain Driving	2	2	
Pulse Duration(tw)	Push-pull Driving (Data Inputs)	43	41	ns
	Open-drain Driving (Data Inputs)	500	500	

7 Electrical Specifications (Continued)

7.3 Switching Characteristics: $V_{CCA}=1.8V \pm 0.15V$

over recommended operating free-air temperature range (unless otherwise noted)

Parameter		Conditions		$V_{CCB}=2.5V \pm 0.2V$	$V_{CCB}=3.3V \pm 0.2V$	$V_{CCB}=5V \pm 0.2V$	Units
				Typ	Typ	Typ	
t_{PHL}	Propagation Delay Time High-to-low Output	A to B	Push-pull Driving	5.6	5	5	ns
			Open-drain Driving	7.5	7.9	8.3	
t_{PLH}	Propagation Delay Time low-to-high Output	A to B	Push-pull Driving	10.0	9.5	9	ns
			Open-drain Driving	181	170	154	
t_{PHL}	Propagation Delay Time High-to-low Output	B to A	Push-pull Driving	7	7.1	7.2	ns
			Open-drain Driving	7.6	8.1	9.2	
t_{PLH}	Propagation Delay Time low-to-high Output	B to A	Push-pull Driving	7.6	6.9	6	ns
			Open-drain Driving	163	145	118	
t_{en}	Enable Time	OE to A or B		135	159	182	ns
t_{dis}	Disable Time	OE to A or B		170	174	181	ns
t_{rA}	Input Rise Time	A port rise time	Push-pull Driving	13.4	11.9	10.6	ns
			Open-drain Driving	68	66	62	
t_{rB}	Input Rise Time	B port rise time	Push-pull Driving	13	12	11.6	ns
			Open-drain Driving	66	65	50	
t_{fA}	Input Fall Time	A port fall time	Push-pull Driving	5.6	4.7	4.0	ns
			Open-drain Driving	5.0	5.1	5.2	
t_{fB}	Input Fall Time	B port fall time	Push-pull Driving	3.0	3.0	2.9	ns
			Open-drain Driving	6.1	5.6	4.4	
$t_{SK(O)}$	Skew(time), Output	Channel-to-Channel Skew		0.5	0.5	0.5	ns
Maximum Data Rate		Push-pull Driving		22	23	24	Mbps
		Open-drain Driving		2	2	2	

7 Electrical Specifications (Continued)

7.4 Switching Characteristics, $V_{CCA}=2.5V \pm 0.15V$

over operating free-air temperature range (unless otherwise noted)

Parameter		Conditions		$V_{CCB}=2.5V \pm 0.2V$	$V_{CCB}=3.3V \pm 0.2V$	$V_{CCB}=5V \pm 0.2V$	Units
				Typ	Typ	Typ	
t_{PHL}	Propagation Delay Time High-to-low Output	A to B	Push-pull Driving	3.5	3.5	3.2	ns
			Open-drain Driving	6.3	6.5	6.7	
t_{PLH}	Propagation Delay Time low-to-high Output	A to B	Push-pull Driving	4.5	4.9	4.7	ns
			Open-drain Driving	158	152	142	
t_{PHL}	Propagation Delay Time High-to-low Output	B to A	Push-pull Driving	3.7	3.9	4.6	ns
			Open-drain Driving	6	6.6	7.7	
t_{PLH}	Propagation Delay Time low-to-high Output	B to A	Push-pull Driving	4.8	4	2.5	ns
			Open-drain Driving	153	138	116	
t_{en}	Enable Time	OE to A or B		7.7	41.8	130	ns
t_{dis}	Disable Time	OE to A or B		175	181	182	ns
t_{rA}	Input Rise Time	A port Rise Time	Push-pull Driving	9.8	8.6	7.5	ns
			Open-drain Driving	79	77	65	
t_{rB}	Input Rise Time	B port Rise Time	Push-pull Driving	9.8	8.7	8.1	ns
			Open-drain Driving	93	68	53	
t_{fA}	Input Fall Time	A port Fall Time	Push-pull Driving	4.6	4.1	3.6	ns
			Open-drain Driving	5.1	5.1	5.2	
t_{fB}	Input Fall Time	B port Fall Time	Push-pull Driving	4.5	4.0	4.0	ns
			Open-drain Driving	6.9	7.4	7.8	
$t_{SK(O)}$	Skew(time), Output	Channel-to-Channel Skew		0.5	0.5	0.5	ns
Maximum Data Rate		Push-pull Driving		22	24	24	Mbps
		Open-drain Driving		2	2	2	

7 Electrical Specifications (continued)

7.5 Switching Characteristics, $V_{CCA} = 3.3V \pm 0.3V$

over recommended operating free-air temperature range (unless otherwise noted)

Parameter		Conditions		$V_{CCB}=3.3V \pm 0.2V$	$V_{CCB}=5V \pm 0.2V$	Units
				TYP	TYP	
t_{PHL}	Propagation Delay Time High-to-low Output	A to B	Push-pull Driving	2.1	2.2	ns
			Open-drain Driving	5.9	6.1	
t_{PLH}	Propagation Delay Time High-to-low Output	A to B	Push-pull Driving	1	3.3	ns
			Open-drain Driving	138	131	
t_{PHL}	Propagation Delay Time High-to-low Output	B to A	Push-pull Driving	2.3	2.6	ns
			Open-drain Driving	5.4	6.6	
t_{PLH}	Propagation delay time low-to-high Output	B to A	Push-pull Driving	1.0	1.0	ns
			Open-drain Driving	133	115	
t_{en}	Enable Time	OE to A or B		4.7	5.2	ns
t_{dis}	Disable Time	OE to A or B		174	182	ns
t_{rA}	Input Rise Time	A port Rise Time	Push-pull Driving	7.4	6.6	ns
			Open-drain Driving	75	67	
t_{rB}	Input Rise Time	B port Rise Time	Push-pull Driving	7.7	7.1	ns
			Open-drain Driving	70	65	
t_{fA}	Input Fall Time	A port Fall Time	Push-pull Driving	3.4	3.0	ns
			Open-drain Driving	5.1	5.1	
t_{fB}	Input Fall Time	B port Fall Time	Push-pull Driving	3.5	3.2	ns
			Open-drain Driving	6.8	6.7	
$t_{SK(O)}$	Skew(time), Output	Channel-to-Channel Skew		0.5	0.5	ns
Maximum Data Rate		Push-pull Driving		24	24	Mbps
		Open-drain Driving		2	2	

8 Typical Characteristics

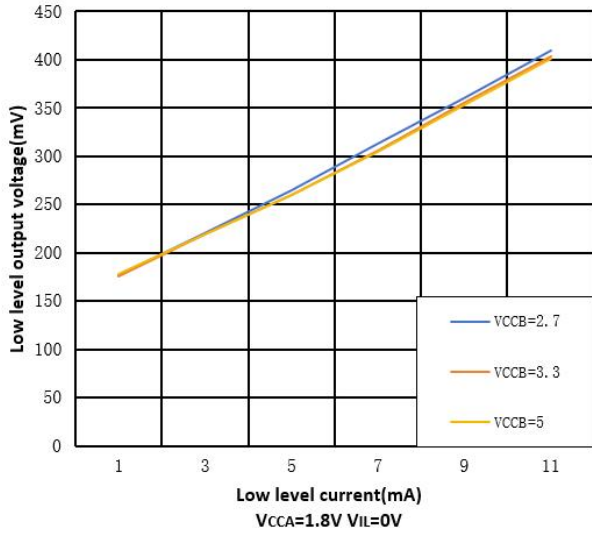

Fig.8-1. Low Level Output Voltage vs Low Level Current

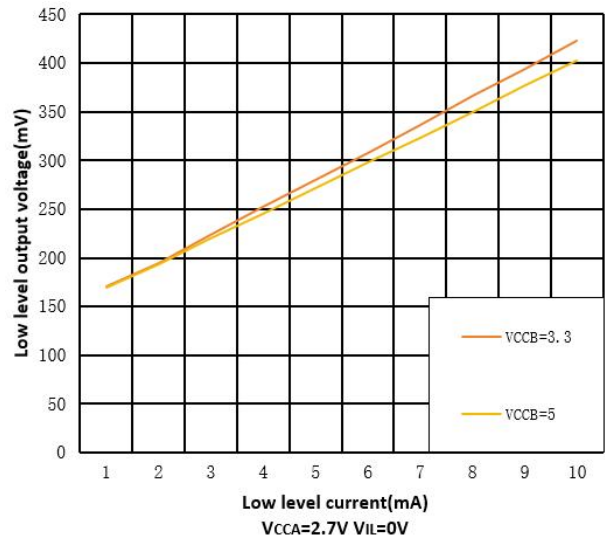

Fig.8-2. Low Level Output Voltage vs Low Level Current

9 Parameter Measurement Information

Unless otherwise noted, all input pulses are supplied by generators having the following characteristics:

- PSRR 10MHz
- $Z_o=50 \Omega$
- $dv/dt \geq 1V/ns$

Note: All input pulses are measured one at a time with one transition per measurement

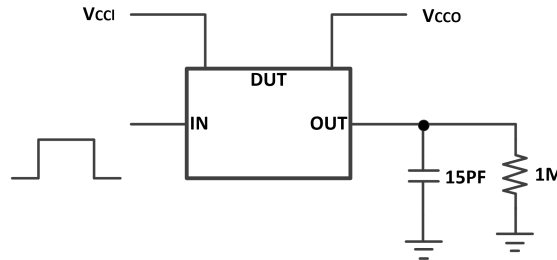

Fig.9-1. Data Rate, Pulse Duration, Propagation Delay, Output Rise and Fall Time Measurement Using a Push-Pull Driver

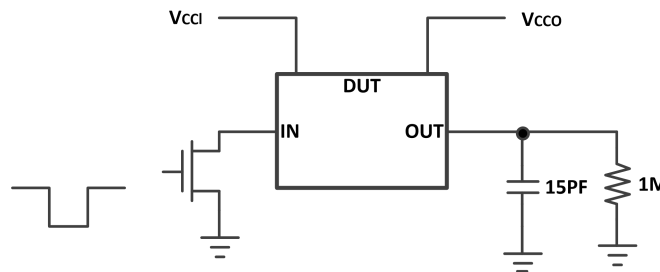

Fig.9-2. Data Rate, Pulse Duration, Propagation Delay, Output Rise and Fall Time Measurement Using an Open-Drain Driver

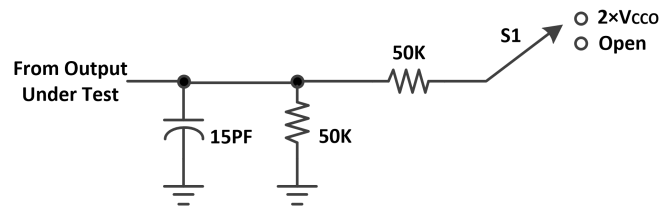

Fig.9-3. Load Circuit for Enable/Disable Time Measurement

Table 9-1 Switch Configuration for Enable/Disable Timing

Test	S1
$t_{PZL}^{(1)}, t_{PLZ}^{(2)}$	$2 \times V_{CCO}$
$t_{PHZL}^{(1)}, t_{PHZ}^{(2)}$	Open

(1) t_{PZL} and t_{PHZ} are the same as t_{en} .

(2) t_{PLZ} and t_{PHZ} are the same as t_{dis} .

9 Parameter Measurement Information (Continued)

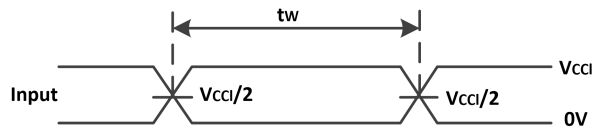

(1) All input pulses are measured one at a time, with one transition per measurement.

Fig.9-4. Voltage Waveforms Pulse Duration

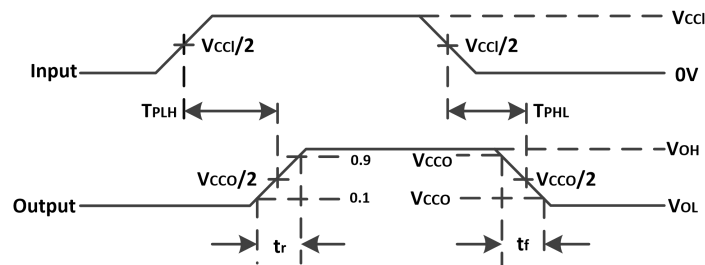

Fig.9-5. Voltage Waveforms Propagation Delay Times

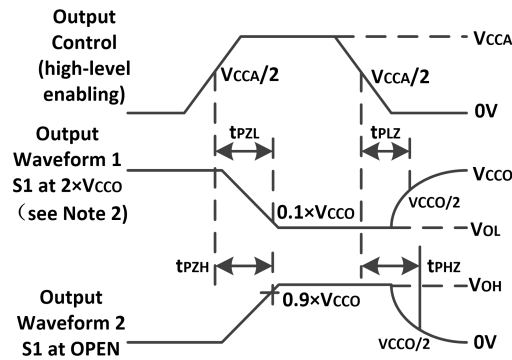

Fig.9-6. Voltage Waveforms Enable and Disable

10 Detailed Description

10.1 Overview

The GT0108 IC is a Bi-direction voltage-level translator specifically designed for translating logic voltage levels. The A port can accept I/O voltages that cover from 1.65 V to 3.6 V range; The B port can accept I/O voltages from 2.3 V to 5.5 V. The device is a pass-gate architecture with edge-rate accelerators (one-shots) to improve the overall data rate. 10-kΩ pullup resistors that usually used in open-drain applications have been integrated inside IC with the advantage saving an external resistor. Not only the IC is designed for open-drain applications, but also this device can translate push-pull CMOS logic outputs.

10.2 Architecture

The GT0108 architecture (see Figure below) is a translator with Bi-direction-Sensing function that means a direction-control mechanism to control the direction of data flow from A to B or from B to A is not needed. These two bidirectional channels independently determine the direction of data flow without a direction-control signal. This auto-direction feature is realized by each I/O pin can be automatically reconfigured as either an input or an output.

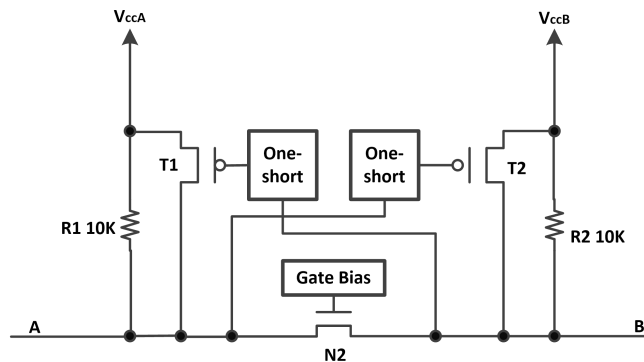

Fig.10-1. Architecture of GT0108

11 Application Information

The GT0108 device can be used to bridge the digital-switching compatibility gap between two voltage nodes to successfully interface logic threshold levels found in electronic systems. It should be used in a point-to-point topology for interfacing devices or systems operating at different interface voltages with one another. Its primary target application use is for interfacing with open-drain drivers on the data I/Os such as I2C or 1-wire, where the data is bidirectional and no control signal is available. The device can also be used in applications where a push-pull driver is connected to the data I/Os, but the GT0108 might be a better option for such push-pull applications.

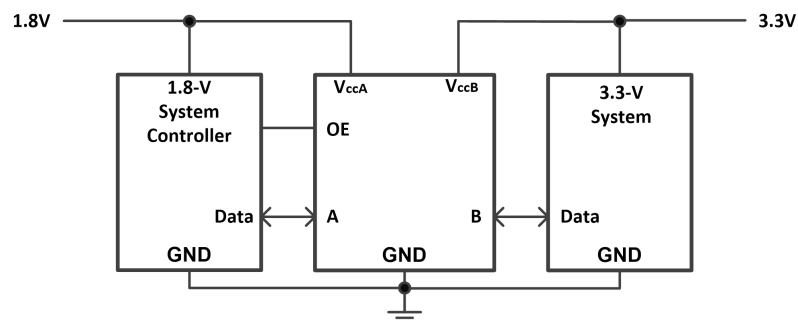
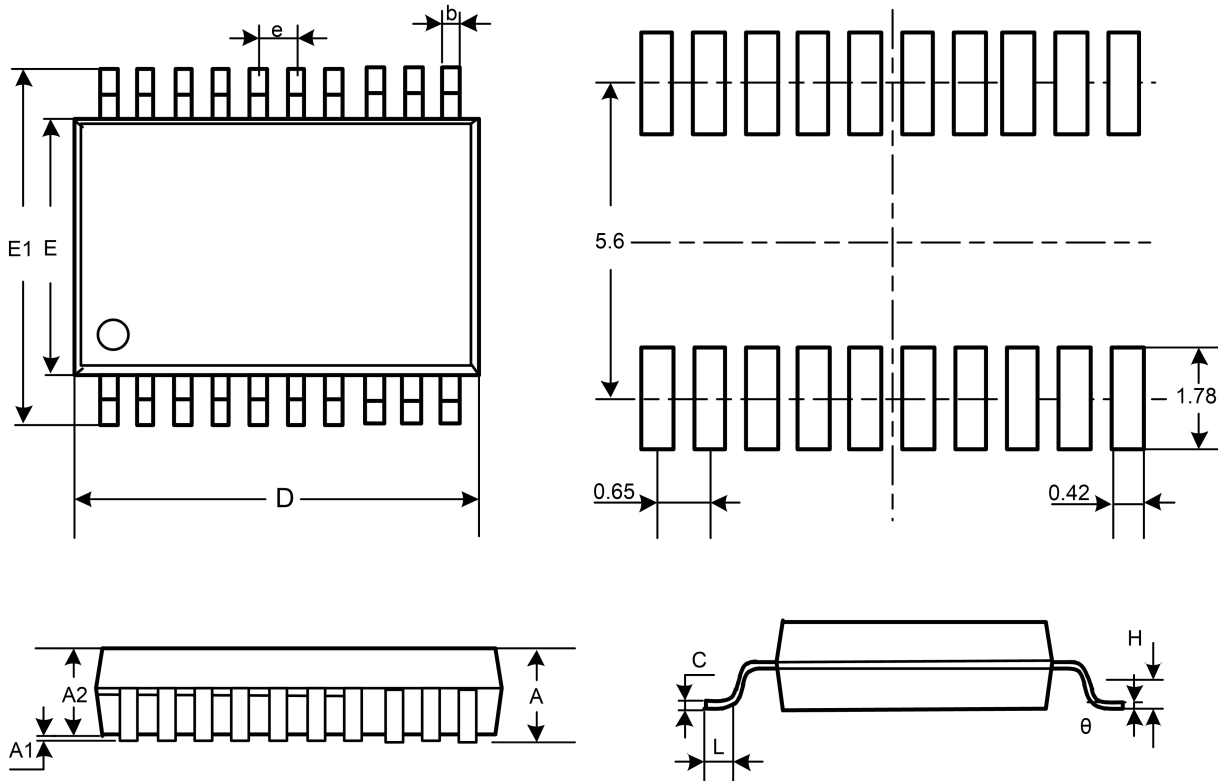

Fig.11-1. Typical Application Schematic

12 Package Outline Dimension

TSSOP-20



Symbol	Dimensions In Millimeters		Dimensions In Inches	
	Min	Max	Min	Max
A		1.200		0.047
A1	0.050	0.150	0.002	0.006
A2	0.800	1.050	0.031	0.041
b	0.200	0.280	0.008	0.011
c	0.130	0.170	0.005	0.007
D	6.400	6.600	0.252	0.260
E	4.300	4.500	0.169	0.177
E1	6.200	6.600	0.244	0.260
e	0.65BSC		0.026BSC	
L	0.450	0.750	0.018	0.030
H	0.25TYP		0.01TYP	
θ	0°	8°	0°	8°

12 Package Outline Dimension(Continued)

QFN3×3-20L

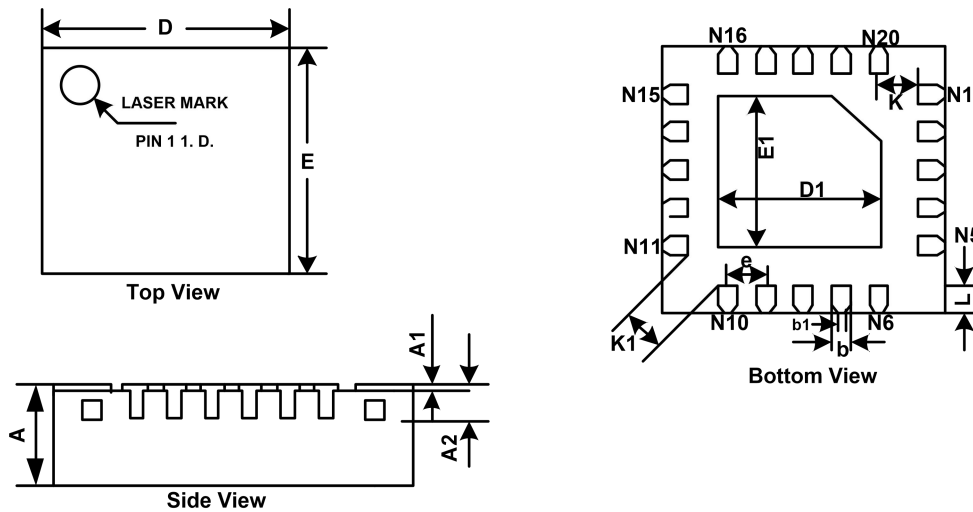

Symbol	Dimensions In Millimeters		Dimensions In Inches	
	Min	Max	Min	Max
A	0.700	0.800	0.028	0.031
A1	0.000	0.050	0.000	0.002
A2	0.203REF		0.008REF	
D	2.950	3.050	0.116	0.120
E	2.950	3.050	0.116	0.120
D1	1.550	1.650	0.061	0.065
E1	1.550	1.650	0.061	0.065
K	0.300REF		0.012REF	
K1	0.400REF		0.016REF	
b	0.150	0.250	0.006	0.010
b1	0.150REF		0.006REF	
e	0.400BSC		0.016BSC	
L	0.350	0.450	0.014	0.018

13 Tape and Reel Information

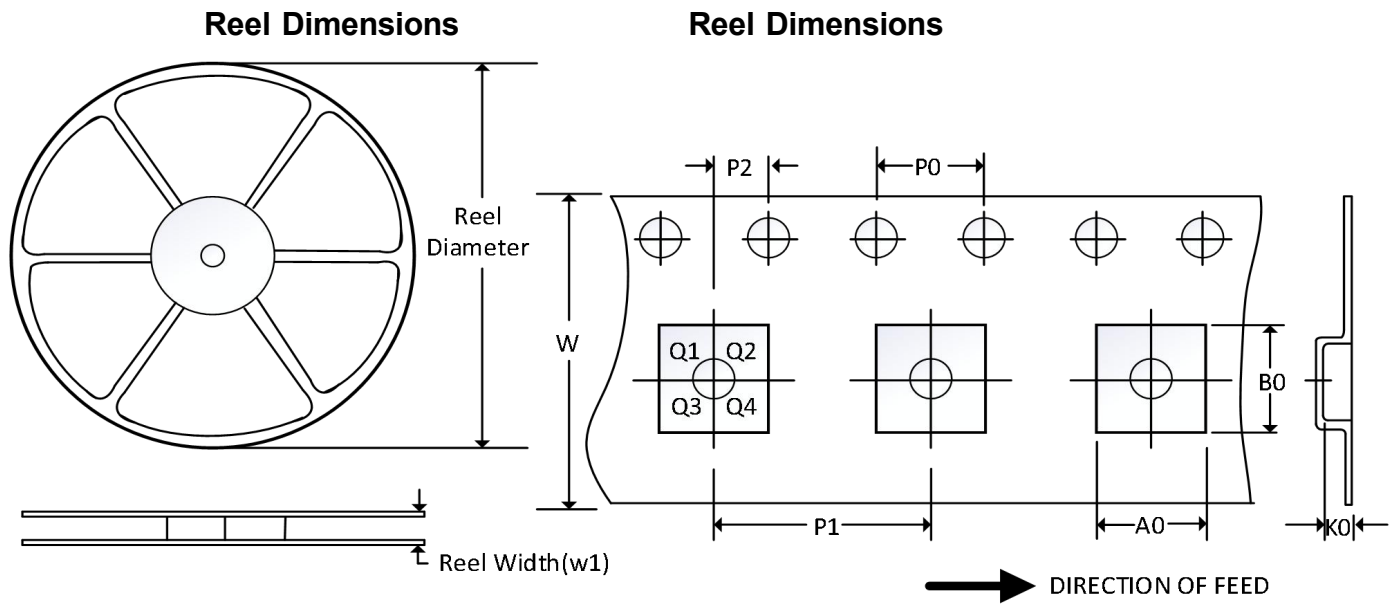

Note: The picture is only for reference. Please make the object as the standard.

Key Parameter List of Tape and Reel

Package type	Reel diameter	Reel width (mm)	A0 (mm)	B0 (mm)	K0 (mm)	P0 (mm)	P1 (mm)	P2 (mm)	W (mm)	Pin1 QuAdrant
TSSOP-20	13"	12.4	6.75	6.95	1.20	4.0	8.0	2.0	12.0	Q1
QFN3X3-20L	13"	12.4	3.35	3.35	1.13	4.0	8.0	2.0	12.0	Q1

Note:
 (1) All dimensions are nominal.
 (2) Plastic or metal protrusions of 0.15mm maximum per side are not included.