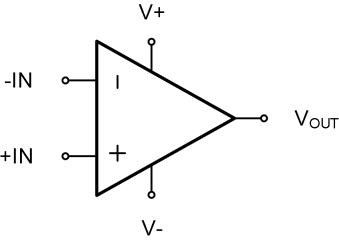


LMV321 LMV358 LMV324

Low-Voltage, Low-Power, Rail-to-Rail I/O CMOS Op Amps

1 Features	2 Application
<ul style="list-style-type: none"> - High gain bandwidth: 1.6 MHz - Rail-to-rail input and output - Low supply current: 65 μA/amplifier at 5 V - Input voltage range: -0.1 V to +5.6 V with $V_S=5.5$ V - Supply range: +2.0 V to +5.5 V - Operation temperature range: -40°C to +125°C 	<ul style="list-style-type: none"> - Sensors - Photodiode amplification - Active filters - Test equipment - Driving A/D converters

3 Description	Circuit Diagram
<p>The LMV3XX families of products offer low voltage operation and rail-to-rail input and output, as well as excellent speed/power consumption ratio, providing an excellent bandwidth (1.6MHz) and slew rate of 0.6V/μs. The op-amps are unity gain stable and feature an ultra-low input bias current.</p> <p>The devices are ideal for sensor interfaces, active filters and portable applications. The LMV3XX families of operational amplifiers are specified at the temperature range of -40°C to +125°C under single or dual power supplies of 2.0V to 5.5V.</p>	

4 Device Summary, Pin and Packages

Table. 4-1. Device Summary⁽¹⁾

Serial Name	Part Name	Package	Body Size (Nom)	Marking ⁽²⁾	MSL ⁽³⁾	Package Qty
LMV321	LMV321C5	SC70-5	2.10mm×1.25mm×1.00mm	LMV321 XXXXX	3	Tape and Reel,3000
	LMV321S5	SOT23-5	2.90mm×1.60mm×1.10mm	LMV321 XXXXX	3	Tape and Reel,3000
	LMV321BC5	SC70-5	2.10mm×1.25mm×1.00mm	LMV321B XXXXX	3	Tape and Reel,3000
	LMV321BS5	SOT23-5	2.90mm×1.60mm×1.10mm	LMV321B XXXXX	3	Tape and Reel,3000
	LMV321M8	MSOP8	3.00mm×3.00mm×1.10mm	LMV321 XXXXXXXX	3	Tape and Reel,4000
	LMV321P8	SOP8	6.00mm×3.90mm×1.75mm	LMV321 XXXXXXXX	3	Tape and Reel,4000
LMV358	LMV358M8	MSOP8	3.00mm×3.00mm×1.10mm	LMV358 XXXXXXXX	3	Tape and Reel,4000
	LMV358P8	SOP8	6.00mm×3.90mm×1.75mm	LMV358 XXXXXXXX	3	Tape and Reel,4000
	LMV358F8	DFN2×2-8	2.00mm×2.00mm×0.75mm	LMV358 XXXX	3	Tape and Reel,3000
LMV324	LMV324TD	TSSOP14	5.00mm×4.40mm×1.20mm	LMV324 XXXXXXXX	3	Tape and Reel,4000
	LMV324PD	SOP14	8.65mm×3.90mm×1.75mm	LMV324 XXXXXXXX	3	Tape and Reel,4000
	LMV324QE	QFN3×3-16L	3.00mm×3.00mm×0.75mm	LMV324 XXXXX	3	Tape and Reel,5000

(1) For all available packages, please contact product sales.

(2) There may be additional marking, which relates to the lot trace code information (data code and vendor code), the logo or the environmental category on the device.

(3) MSL, The Moisture Sensitivity Level rating according to the JEDEC industry standard classifications.

(4) "XXXXX" in Marking will be appeared as the batch code.

4 Device Summary, Pin and Packages(Continued)

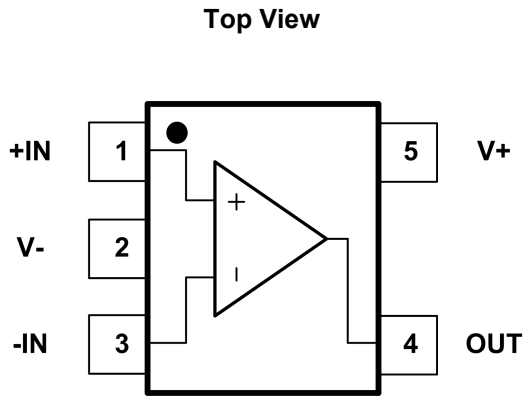


Fig.4-1. LMV321: C5 (SC70-5) Package
LMV321: S5 (SOT23-5) Package

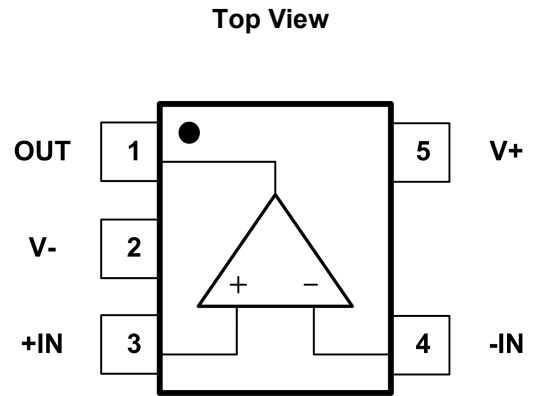


Fig.4-2. LMV321B: C5 (SC70-5) Package
LMV321B: S5 (SOT23-5) Package

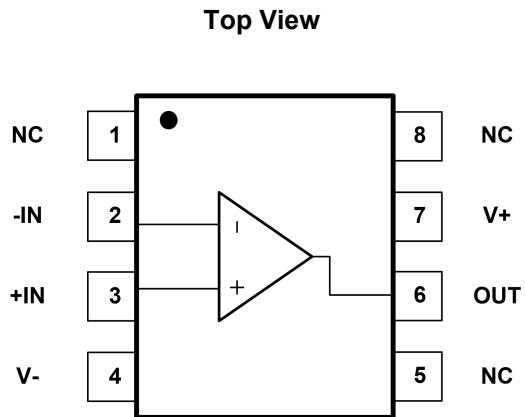


Fig.4-3. LMV321: M8 (MSOP8) Package
LMV321: P8 (SOP8) Package

Table. 4-2. Pin Definition

Name	Pin			I/O	Description
	C5 S5	BC5 BS5	M8 P8		
-IN	3	4	2	I	Inverting input
+IN	1	3	3	I	Noninverting input
NC	-	-	1,5,8	-	No internal connection (can be left floating)
OUT	4	1	6	O	Output
V-	2	2	4	-	Negative (lowest) supply or ground (for single-supply operation)
V+	5	5	7	-	Positive (highest) supply

* It is suggested to leave the unconnected pins floating.

4 Device Summary, Pin and Packages(Continued)

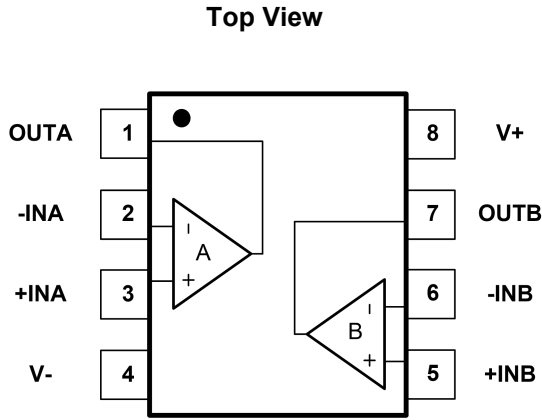


Fig.4-4.LMV358: M8(MSOP8) Package
LMV358: P8(SOP8) Package

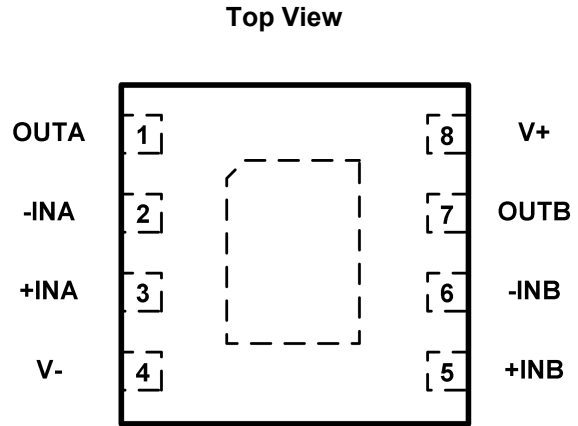


Fig. 4-5. LMV358: F8(DFN2x2-8) Package

Table. 4-3. Pin Definition

Pin		I/O	Description
Name	M8 P8 F8		
-INA	2	I	Inverting input, channel A
+INA	3	I	Noninverting input, channel A
-INB	6	I	Inverting input, channel B
+INB	5	I	Noninverting input, channel B
OUTA	1	O	Output, channel A
OUTB	7	O	Output, channel B
V-	4	-	Negative (lowest) supply or ground (for single-supply operation)
V+	8	-	Positive (highest) supply

* It is suggested to leave the unconnected pins floating.

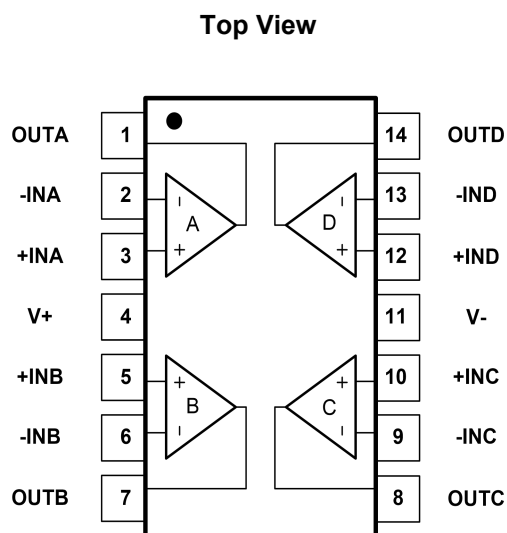
4 Device Summary, Pin and Packages(Continued)


Fig.4-6. LMV324: TD (TSSOP14) Package
LMV324: PD (SOP14) Package

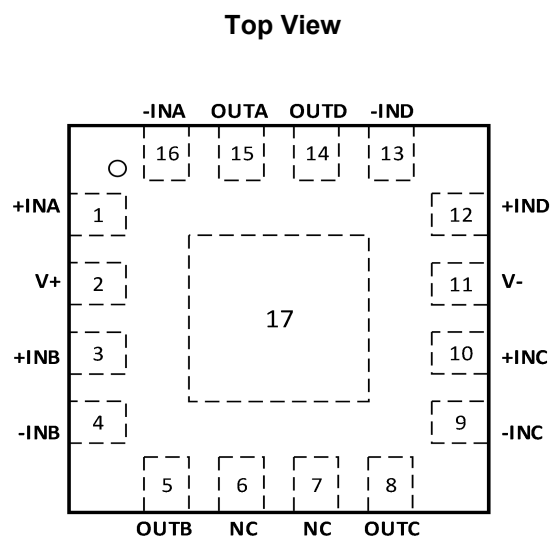


Fig.4-7. LMV324: QE (QFN3x3-16L) Package

Table. 4-4. Pin Definition

Pin			I/O	Description
Name	TD PD	QE		
-INA	2	16	I	Inverting input, channel A
+INA	3	1	I	Noninverting input, channel A
-INB	6	4	I	Inverting input, channel B
+INB	5	3	I	Noninverting input, channel B
-INC	9	9	I	Inverting input, channel C
+INC	10	10	I	Noninverting input, channel C
-IND	13	13	I	Inverting input, channel D
+IND	12	12	I	Noninverting input, channel D
OUTA	1	15	O	Output, channel A
OUTB	7	5	O	Output, channel B
OUTC	8	8	O	Output, channel C
OUTD	14	14	O	Output, channel D
V-	11	11	-	Negative (lowest) supply or ground (for single-supply operation)
V+	4	2	-	Positive (highest) supply
NC	/	6,7	-	No internal connection (can be left floating)

* It is suggested to leave the unconnected pins floating.

5 Voltage, Temperature, ESD and Thermal Ratings

5.1 Absolute Maximum Ratings⁽¹⁾

Parameters	Min.	Max.	Unit
Supply Voltage $V_s=(V^+)-(V^-)$		6.5	V
Select Input Voltage ⁽²⁾	$(V^-)-0.5$	$(V^+)+0.5$	V
Maximum Junction Temperature	-55	150	°C
Storage Temperature Range	-55	150	°C

(1) Stresses above these ratings may cause permanent damage. Exposure to absolute maximum conditions for extended periods may degrade device reliability. These are stress ratings only, and functional operation of the device at these or any other conditions beyond those specified is not implied.

(2) Input terminals are diode-clamped to the power-supply rails. Input signals that can swing more than 0.3V beyond the supply rails should be current-limited to 10mA or less.

5.2 ESD Ratings

ESD			Value	Unit
V(ESD)	Electrostatic discharge	Human-Body Model (HBM) ⁽¹⁾	7.5 K	V
		Charged-Device Model (CDM) ⁽²⁾	2 K	V

(1) JEDEC document JEP155 states that 500-V HBM allows safe manufacturing with a standard ESD control process.

(2) JEDEC document JEP157 states that 250-V CDM allows safe manufacturing with a standard ESD control process.

5.3 Recommended Operating Conditions

Over operating free-air temperature range (unless otherwise noted)

Symbol	Parameters	Min.	Max.	Unit
Supply Voltage $V_s=(V^+)-(V^-)$	Single-supply	2.0	5.5	V
	Dual-supply	±1.0	±2.75	
TA	Operating temperature	-40	125	°C

5.4 Thermal Information

Package Type	θ_{JA}	θ_{JC}	Unit
SC70-5	400	150	°C/W
SOT23-5	250	81	°C/W
MSOP8	210	45	°C/W
SOP8	158	43	°C/W
DFN2×2-8L	100	60	°C/W
TSSOP14	180	35	°C/W
SOP14	120	36	°C/W

6 Electrical Specifications

$V_{CC}=5.0V$, $V_{cm}=V_{CC}/2$, $V_o=V_{CC}/2$, and $R_L=10k\Omega$, FULL= $-40^{\circ}C$ to $+125^{\circ}C$, Typical values are at $T_A=+25^{\circ}C$. (unless otherwise noted)

Parameters	Symbol	Conditions	V_{CC}	T_A	Min.	Typ.	Max.	Unit
Power Supply								
Quiescent Current/amplifier	I_Q		5V	$+25^{\circ}C$		65	100	μA
Operating Voltage Range	V_s			FULL	2.0		5.5	V
Power-supply Rejection Ratio	PSRR		5V	$+25^{\circ}C$	75	95		dB
Offset Voltage								
Input Offset Voltage	V_{os}		5V	$+25^{\circ}C$	-2	0.5	2	mV
Input Offset Voltage Average Drift	$V_{os\ TC}$	$-40^{\circ}C$ to $+125^{\circ}C$	5V			± 3		$\mu V/^{\circ}C$
Input								
Common-mode Voltage Range	V_{cm}		5.5V	FULL	-0.1		5.6	V
Common-mode Rejection Ratio	CMRR	$V_{cm} = -0.1V$ to $4V$	5.5V	$+25^{\circ}C$	65	85		dB
		$V_{cm} = -0.1V$ to $5.6V$		$+25^{\circ}C$	60	80		
Input Bias Current	I_B			$+25^{\circ}C$		10		pA
Input Offset Current	I_{os}			$+25^{\circ}C$		10		pA
Noise								
Input Voltage Noise(rms)	E_N	$f=0.1Hz$ to $10Hz$	5V	$+25^{\circ}C$		1.4		μV_{rms}
Input Voltage Noise Density	e_N	$f=1kHz$	5V	$+25^{\circ}C$		35		nV/\sqrt{Hz}
		$f=10kHz$				12		
Output								
Open-loop Voltage Gain	AOL	$R_L=2K\Omega$, $V_o=0.15V$ to $4.85V$	5V	$+25^{\circ}C$	90	110		dB
		$R_L=10K\Omega$, $V_o=0.05V$ to $4.95V$	5V	$+25^{\circ}C$	95	115		
Output Swing From Rail	V_o	$R_L=10k\Omega$	5V	$+25^{\circ}C$		4.5		mV
		$R_L=2k\Omega$				15		
Output Current	I_{out}		5V	$+25^{\circ}C$		75		mA
Frequency Response								
Gain Bandwidth Product	GBP		5V	$+25^{\circ}C$		1.6		MHz
Phase Margin	PM		5V	$+25^{\circ}C$		60		$^{\circ}$
Slew Rate	SR		5V	$+25^{\circ}C$		0.6		$V/\mu s$

7 Typical Characteristics

$V_{cc}=5.0V$, $V_{cm}=V_{cc}/2$, $V_o=V_{cc}/2$, and $R_L=10k\Omega$, FULL $=-40^{\circ}C$ to $+125^{\circ}C$, Typical values are at $T_A=+25^{\circ}C$. (unless otherwise noted)

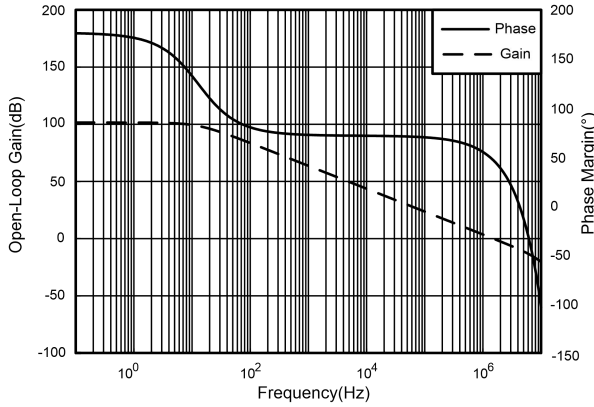


Fig.7-1. Open-Loop Gain and Phase vs Frequency

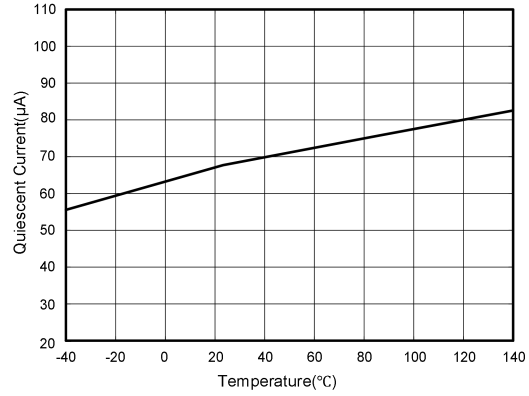


Fig.7-2. Quiescent Current vs Temperature

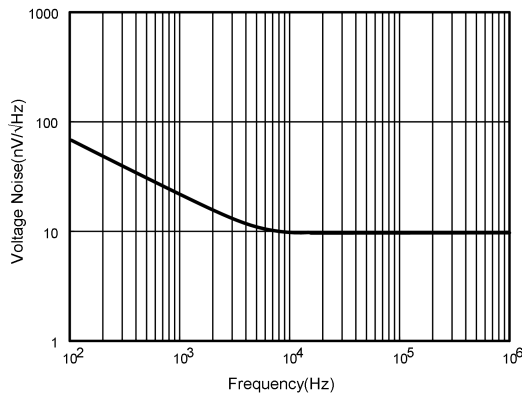


Fig.7-3. Voltage Noise vs Frequency

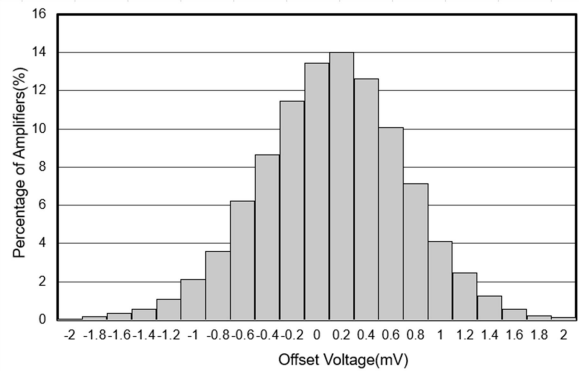


Fig.7-4. Offset Voltage Production Distribution(LMV321)

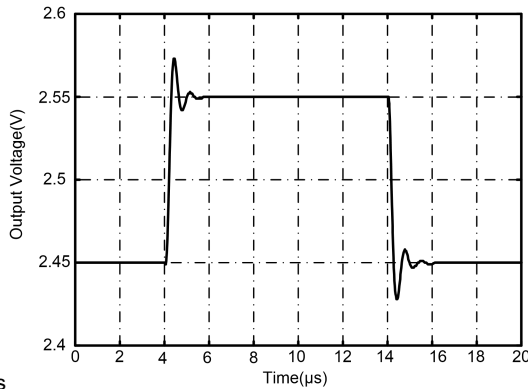


Fig.7-5. Small-Signal Step Response

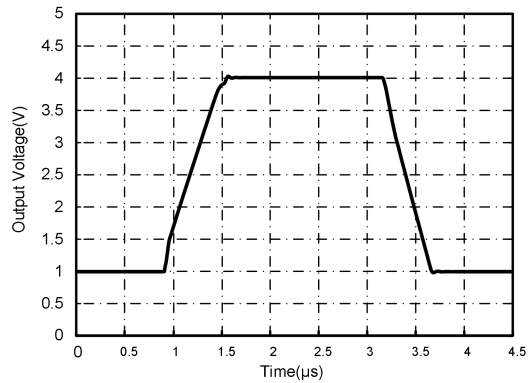


Fig.7-6. Large-Signal Step Response

8 Detailed Description

The LMV3XX families of products are rail-to-rail operational amplifiers that can be run from a single-supply voltage 2.0V to 5.5V ($\pm 1.0V$ to $\pm 2.75V$). Supply voltages higher than 6.5V (absolute maximum) can permanently damage the amplifier. Rail-to-rail input and output swing significantly increases dynamic range, especially in low-supply applications.

Attention to good layout practices is always recommended. Keep traces short. When possible, use a PCB ground plane with surface-mount components placed as close to the device pins as possible. Place a 0.1 μ F capacitor closely across the supply pins. These guidelines should be applied throughout the analog circuit to improve performance and provide benefits such as reducing the EMI susceptibility.

9 Application Note

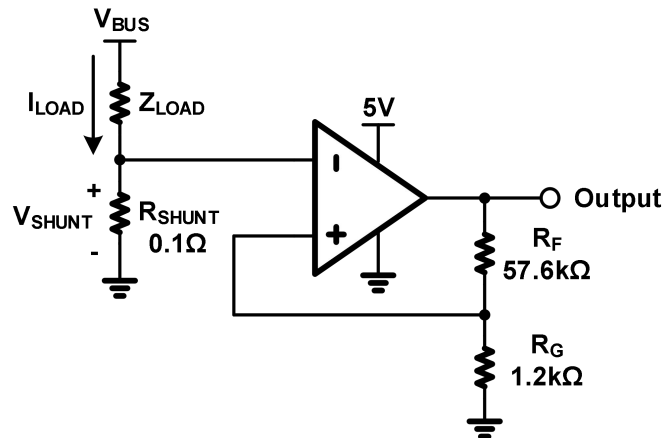
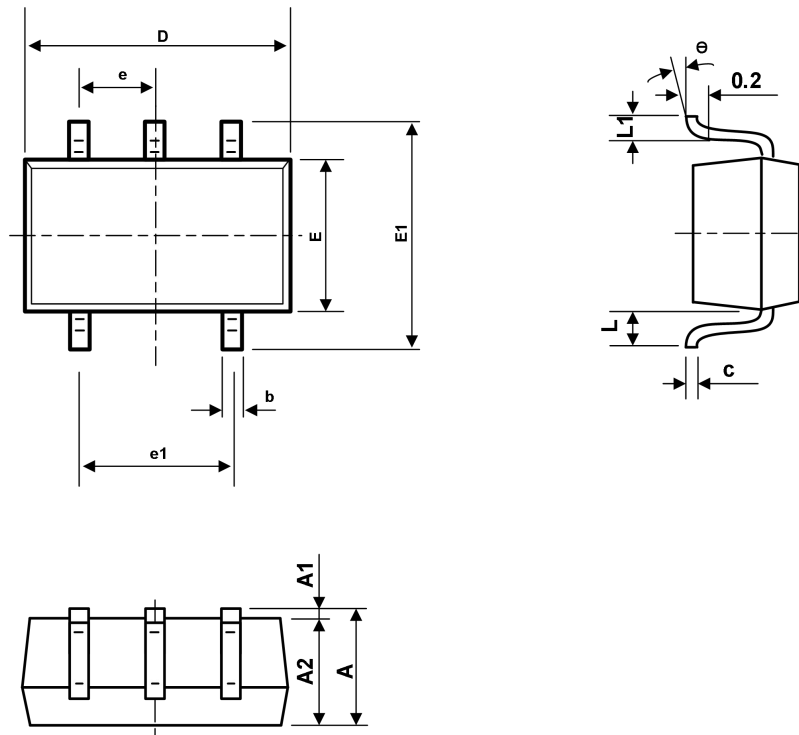


Fig.9-1. A Low-Side, Current-Sensing Application

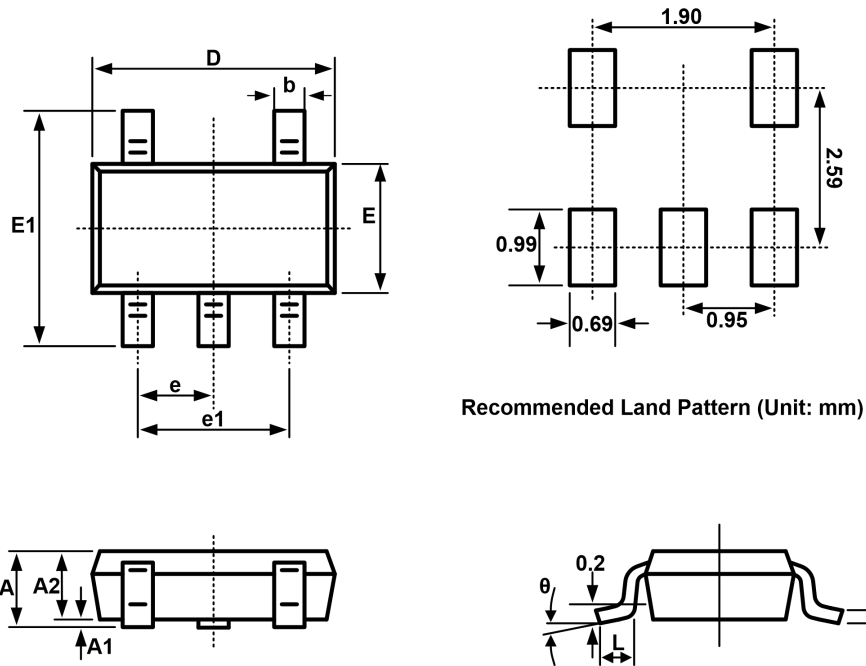
Fig.9-1 shows the LMV3XX configured in a low-side current sensing application.

Use the following parameters for this design example:

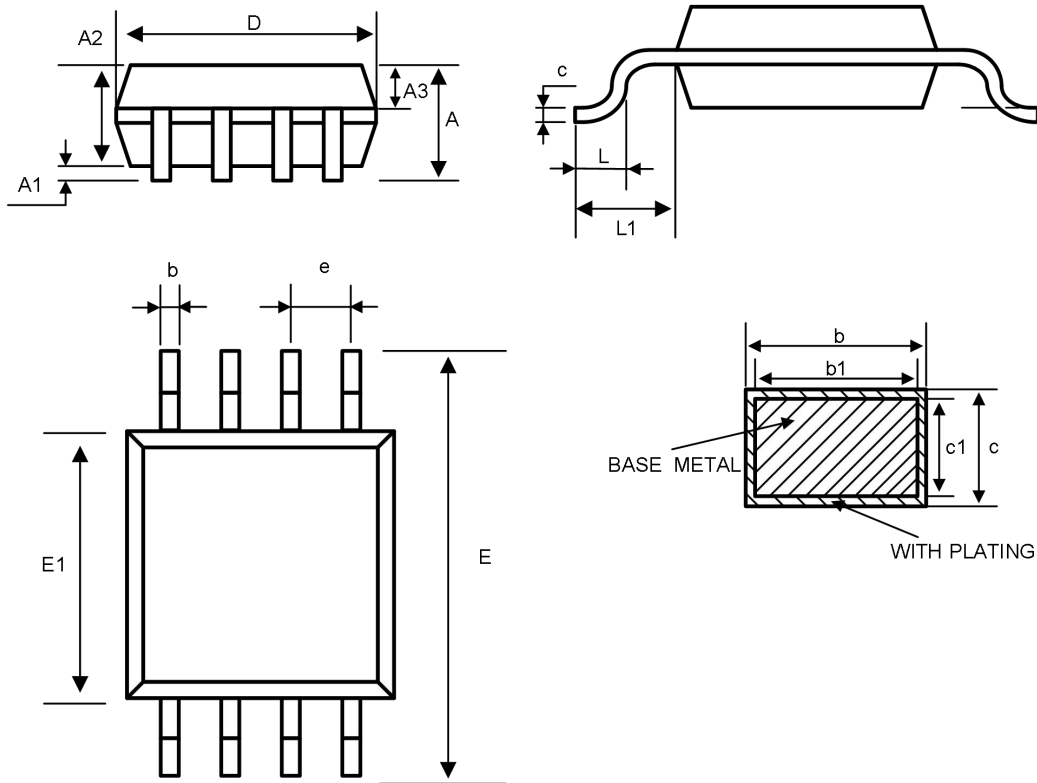
- Load current: 0 A to 1 A
- Output voltage: 4.9 V
- Maximum shunt voltage: 100 mV

10 Package Outline Dimension
SC70-5


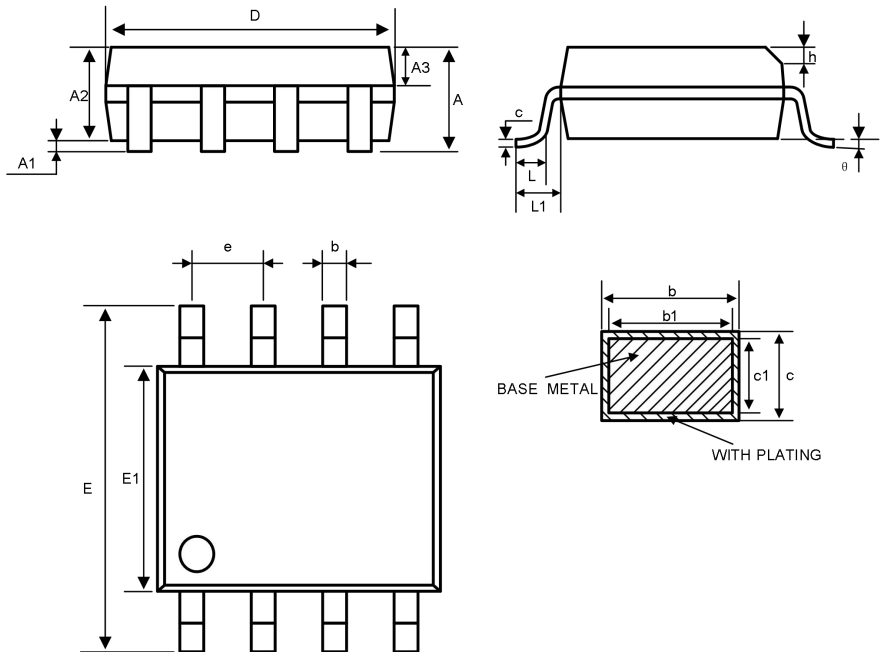
Symbol	Dimensions in Millimeters		Dimensions in Inches	
	Min.	Max.	Min.	Max.
A	0.900	1.100	0.035	0.043
A1	0.000	0.100	0.000	0.004
A2	0.900	1.000	0.035	0.039
b	0.150	0.350	0.006	0.014
c	0.110	0.175	0.004	0.007
D	2.000	2.200	0.079	0.087
E	1.150	1.350	0.045	0.053
E1	2.150	2.450	0.085	0.096
e	0.650TYP		0.026TYP	
e1	1.200	1.400	0.047	0.055
L	0.525REF		0.021REF	
L1	0.260	0.460	0.010	0.018
θ	0°	8°	0°	8°

10 Package Outline Dimension(Continued)
SOT23-5


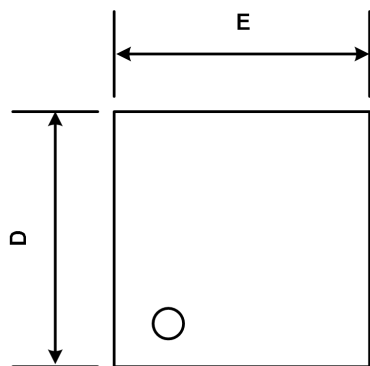
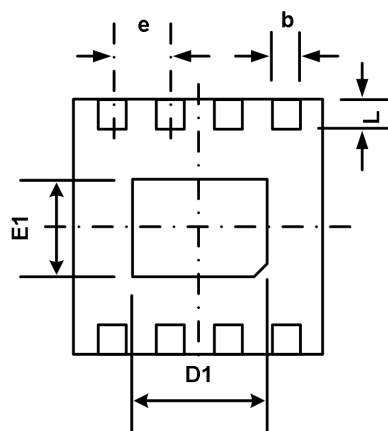
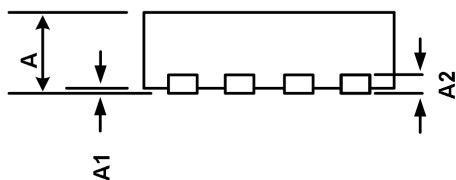
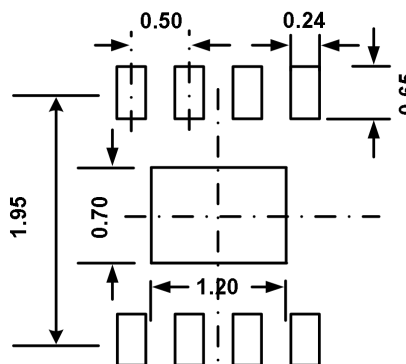
Symbol	Dimensions in Millimeters		Dimensions in Inches	
	Min.	Max.	Min.	Max.
A	1.050	1.250	0.041	0.049
A1	0.000	0.100	0.000	0.004
A2	1.050	1.150	0.041	0.045
b	0.300	0.500	0.012	0.020
c	0.100	0.200	0.004	0.008
D	2.820	3.020	0.111	0.119
E	1.500	1.700	0.059	0.067
E1	2.650	2.950	0.104	0.116
e	0.950(BSC)		0.037(BSC)	
e1	1.800	2.000	0.071	0.079
L	0.300	0.600	0.012	0.024
L1	0.600REF		0.024REF	
θ	0°	8°	0°	8°

10 Package Outline Dimension(Continued)
MSOP8


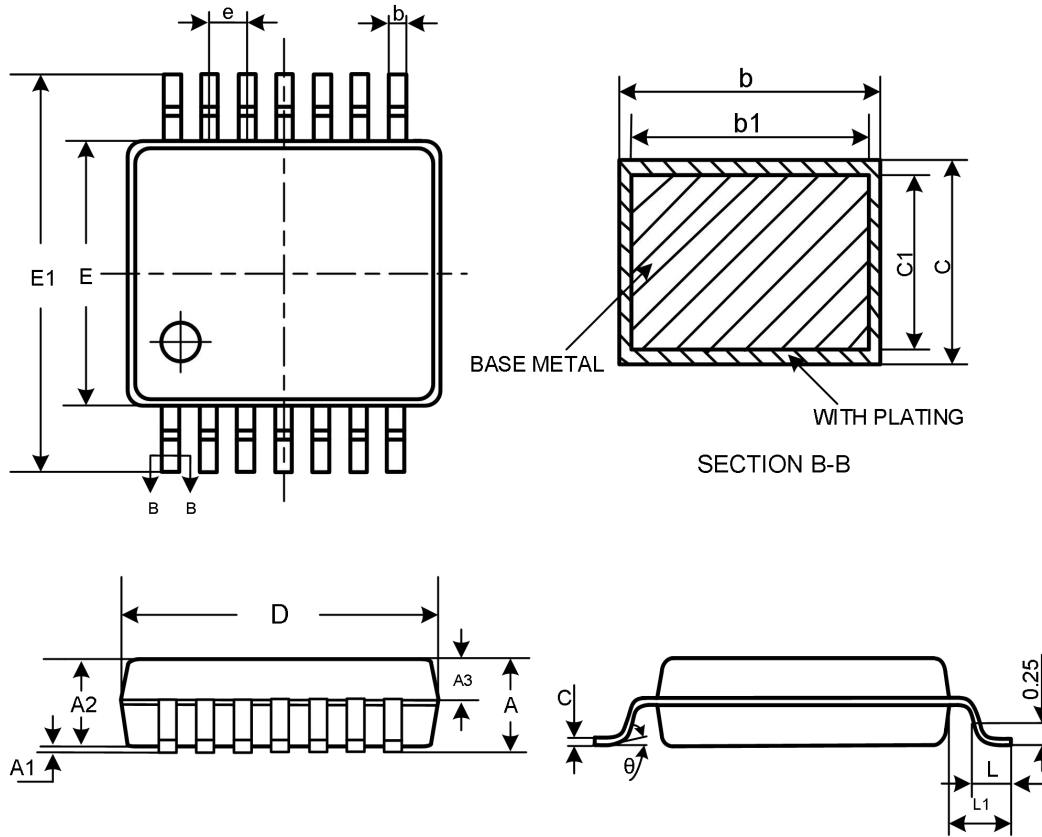
Symbol	Dimensions in Millimeters			Dimensions in Inches		
	Min.	Nom.	Max.	Min.	Nom.	Max.
A	—	—	1.10	—	—	0.043
A1	0.05	—	0.15	0.002	—	0.006
A2	0.75	0.85	0.95	0.030	0.033	0.037
A3	0.30	0.35	0.40	0.012	0.014	0.016
b	0.28	—	0.36	0.011	—	0.014
b1	0.27	0.30	0.33	0.011	0.012	0.013
c	0.15	—	0.19	0.006	—	0.007
c1	0.14	0.15	0.16	0.006	0.006	0.006
D	2.90	3.00	3.10	0.114	0.118	0.122
E	4.70	4.90	5.10	0.185	0.193	0.201
E1	2.90	3.00	3.10	0.114	0.118	0.122
e	0.65BSC			0.026BSC		
L	0.40	—	0.70	0.016	—	0.028
L1	0.95REF			0.037REF		
θ	0	—	8°	0	—	8°

10 Package Outline Dimension(Continued)
SOP8


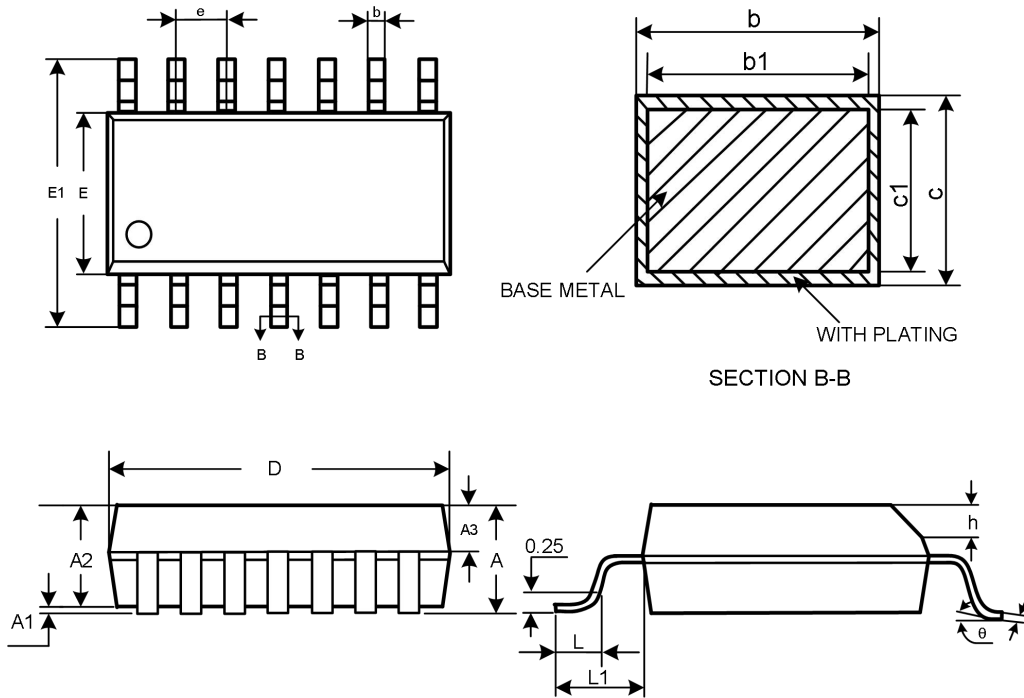
Symbol	Dimensions in Millimeters			Dimensions in Inches		
	Min.	Nom.	Max.	Min.	Nom.	Max.
A	—	—	1.75	—	—	0.069
A1	0.10	—	0.225	0.004	—	0.009
A2	1.30	1.40	1.50	0.051	0.055	0.059
A3	0.60	0.65	0.70	0.024	0.026	0.028
b	0.39	—	0.47	0.015	—	0.019
b1	0.38	0.41	0.44	0.015	0.016	0.017
c	0.20	—	0.21	0.008	—	0.008
c1	4.80	4.90	5.00	0.189	0.193	0.197
D	5.80	6.00	6.20	0.228	0.236	0.244
E	5.80	6.00	6.20	0.228	0.236	0.244
E1	3.80	3.90	4.00	0.150	0.154	0.157
e	1.27BSC			0.05BSC		
h	0.25	—	0.50	0.010	—	0.020
L	0.50	—	0.80	0.020	—	0.031
L1	1.05REF			0.041REF		
Θ	0	—	8°	0	—	8°

10 Package Outline Dimension(Continued)
DFN2×2-8L

TOP VIEW

BOTTOM VIEW

SIDE VIEW

RECOMMENDED LAND PATTERN(unit:mm)

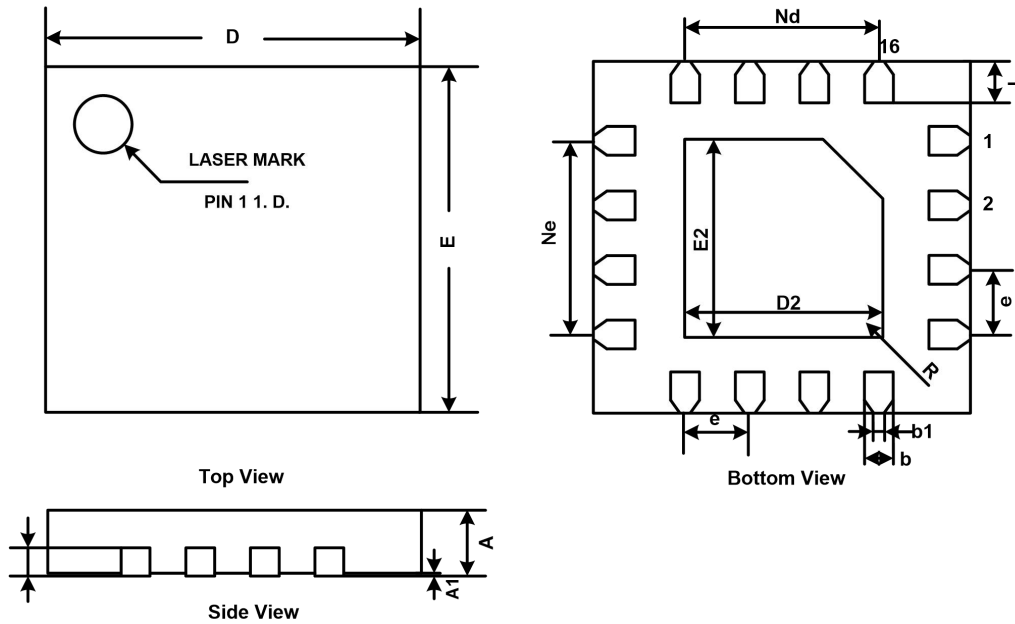
Symbol	Dimensions in Millimeters		Dimensions in Inches	
	Min.	Max.	Min.	Max.
A	0.700	0.800	0.028	0.031
A1	0.000	0.050	0.000	0.002
A2	0.203(TYP)		0.035(TYP)	
b	0.180	0.300	0.007	0.012
D	1.900	2.100	0.075	0.083
D1	1.100	1.300	0.043	0.051
E	1.900	2.100	0.075	0.083
E1	0.600	0.800	0.024	0.031
e	0.500(TYP)		0.020TYP	
L	0.250	0.450	0.010	0.018

10 Package Outline Dimension(Continued)
TSSOP14


SYMBOL	Dimensions in Millimeters			Dimensions in Inches		
	Min.	Nom.	Max.	Min.	Nom.	Max.
A	—	—	1.20	—	—	0.047
A1	0.05	—	0.15	0.002	—	0.006
A2	0.90	1.00	1.05	0.035	0.039	0.041
A3	0.39	0.44	0.49	0.015	0.017	0.019
b	0.20	—	0.28	0.008	—	0.011
b1	0.19	0.22	0.25	0.007	0.009	0.010
c	0.13	—	0.17	0.005	—	0.007
c1	0.12	0.13	0.14	0.005	0.005	0.006
D	4.90	5.00	5.10	0.193	0.197	0.201
E	4.30	4.40	4.50	0.169	0.173	0.177
E1	6.20	6.40	6.60	0.244	0.252	0.260
e	0.65BSC			0.026BSC		
L	0.45	0.60	0.75	0.018	0.024	0.030
L1	1.00BCS			0.039BSC		
θ	0	—	8°	0	—	8°

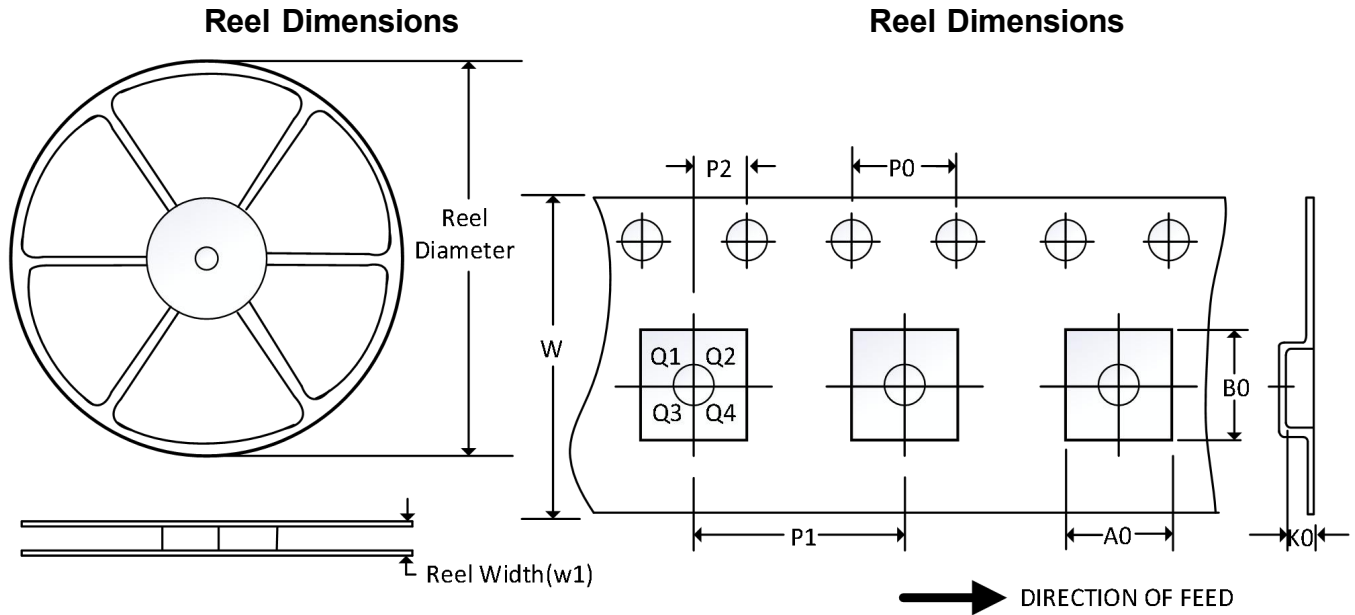
10 Package Outline Dimension(Continued)
SOP14


Symbol	Dimensions in Millimeters			Dimensions in Inches		
	Min.	Nom.	Max.	Min.	Nom.	Max.
A	—	—	1.75	—	—	0.069
A1	0.10	—	0.225	0.004	—	0.009
A2	1.30	1.40	1.50	0.051	0.055	0.059
A3	0.60	0.65	0.70	0.024	0.026	0.028
b	0.39	—	0.47	0.015	—	0.019
b1	0.38	0.41	0.44	0.015	0.016	0.017
c	0.20	—	0.24	0.20	—	0.24
c1	0.19	0.20	0.21	0.007	0.008	0.008
D	8.55	8.65	8.75	0.337	0.341	0.344
E1	5.80	6.00	6.20	0.228	0.236	0.244
E	3.80	3.90	4.00	0.150	0.154	0.157
e	1.27BSC			0.05BSC		
h	0.25	—	0.50	0.010	—	0.020
L	0.50	—	0.80	0.020	—	0.031
L1	1.05REF			0.041REF		
θ	0	—	8°	0	—	8°

10 Package Outline Dimension(Continued)
QFN3×3-16L


Symbol	Dimensions in Millimeters		Dimensions in Inches	
	Min.	Max.	Min.	Min.
A	0.700	0.800	0.028	0.032
A1	0.000	0.050	0.000	0.002
b	0.200	0.300	0.008	0.012
b1	0.230REF		0.009REF	
c	0.203REF		0.008REF	
D	2.900	3.100	0.116	0.124
D2	1.600	1.700	0.064	0.068
e	0.500BSC		0.020BSC	
Nd	1.500BSC		0.060BSC	
Ne	1.500BSC		0.060BSC	
E	2.900	3.100	0.116	0.124
E2	1.600	1.700	0.064	0.068
L	0.350	0.450	0.014	0.018
h	0.250	0.350	0.010	0.014
K	0.225	0.325	0.009	0.013
R	0.075REF		0.003REF	

11 Tape and Reel Information



NOTE: The picture is only for reference. Please make the object as the standard.

Key Parameter List of Tape and Reel

Package Type	Reel Diameter	Reel Width (mm)	A0 (mm)	B0 (mm)	K0 (mm)	P0 (mm)	P1 (mm)	P2 (mm)	W (mm)	Pin1 Quadrant
SC70-5	7"	9.5	2.25	2.55	1.20	4.0	4.0	2.0	8.0	Q3
SOT23-5	7"	9.5	3.20	3.20	1.40	4.0	4.0	2.0	8.0	Q3
MSOP8	13"	12.4	5.20	3.30	1.50	4.0	8.0	2.0	12.0	Q1
SOP8	13"	12.4	6.40	5.40	2.10	4.0	8.0	2.0	12.0	Q1
DFN2×2-8L	7"	9.5	2.30	2.30	1.10	4.0	4.0	2.0	8.0	Q2
TSSOP14	13"	12.4	6.95	5.60	1.20	4.0	8.0	2.0	12.0	Q1
SOP14	13"	16.4	6.60	9.30	2.10	4.0	8.0	2.0	16.0	Q1
QFN3×3-16L	7"	12.0	3.23	3.23	1.05	4.0	4.0	2.0	12.0	Q1

NOTE:

1. All dimensions are nominal.
2. Plastic or metal protrusions of 0.15mm maximum per side are not included.